

12 Clintonville Road
Northford, CT 06472-1653
Phone: 203.484.7161

FCM-1 Supervised Control Module

SPECIFICATIONS

Normal Operating Voltage:	15 to 32 VDC
Maximum Current Draw:	6.5 mA (LED on)
Average Operating Current:	375µA (LED flashing - in group poll mode) 350µA (LED flashing - in direct poll mode); 485µA Max. (LED flashing, NAC shorted)
Maximum NAC Line Loss:	4 VDC
External Supply Voltage (between Terminals T10 and T11)	
Maximum (NAC):	Regulated 24 VDC
Maximum (Speakers):	70.7 V RMS, 50 W
Drain on External Supply:	1.7 mA Maximum using 24 VDC supply; 2.2 mA Maximum using 80 VRMS supply
Max NAC Current Ratings:	For class B wiring system, the current rating is 3A; For class A wiring system, the current rating is 2A
Temperature Range:	32°F to 120°F (0°C to 49°C)
Humidity:	10% to 93% Non-condensing
Dimensions:	4 1/2" H × 4" W × 1 1/4" D (Mounts to a 4" square by 2 1/8" deep box.)
Accessories:	SMB500 Electrical Box; CB500 Barrier

BEFORE INSTALLING

This information is included as a quick reference installation guide. Refer to the control panel installation manual for detailed system information. If the modules will be installed in an existing operational system, inform the operator and local authority that the system will be temporarily out of service. Disconnect power to the control panel before installing the modules.

NOTICE: This manual should be left with the owner/user of this equipment.

GENERAL DESCRIPTION

FCM-1 Supervised Control Modules are intended for use in intelligent, two-wire systems, where the individual address of each module is selected using the built-in rotary switches. This module is used to switch an external power supply, which can be a DC power supply or an audio amplifier (up to 80 VRMS), to notification appliances. It also supervises the wiring to the connected loads and reports their status to the panel as NORMAL, OPEN, or SHORT CIRCUIT. The FCM-1 has two pairs of output termination points available for fault-tolerant wiring and a panel-controlled LED indicator. This module can be used to replace a CMX-2 module that has been configured for supervised wiring operation.

COMPATIBILITY REQUIREMENTS

To ensure proper operation, this module shall be connected to a compatible Notifier system control panels only (list available from Notifier).

MOUNTING

The FCM-1 mounts directly to 4-inch square electrical boxes (see Figure 2A). The box must have a minimum depth of 2 1/8 inches. Surface mounted electrical boxes (SMB500) are available.

WIRING

NOTE: All wiring must conform to applicable local codes, ordinances, and regulations. When using control modules in nonpower limited applications, the CB500 Module Barrier must be used to meet UL requirements for the separation of power-limited and nonpower-limited terminals and wiring. The barrier must be inserted into a 4" × 4" × 2 1/8" junction box, and the control module must be placed into the barrier and attached to the junction box (Figure 2A). The power-limited wiring must be placed into the isolated quadrant of the module barrier (Figure 2B).

1. Install module wiring in accordance with the job drawings and appropriate wiring diagrams.
2. Set the address on the module per job drawings.
3. Secure module to electrical box (supplied by installer), see Figure 2A.

IMPORTANT: When using the FCM-1 for fire fighter telephone applications, remove Jumper (J1) and discard. The Jumper is located on the back as shown in Figure 1B. The module does not provide ring back when used as a fire-fighter telephone circuit.

FIGURE 1A:

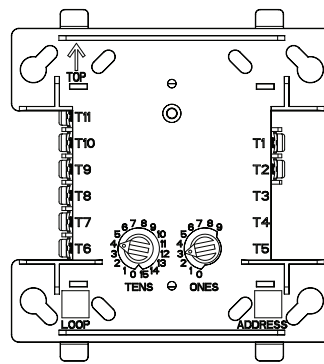

FIGURE 2A. MODULE MOUNTING WITH BARRIER:

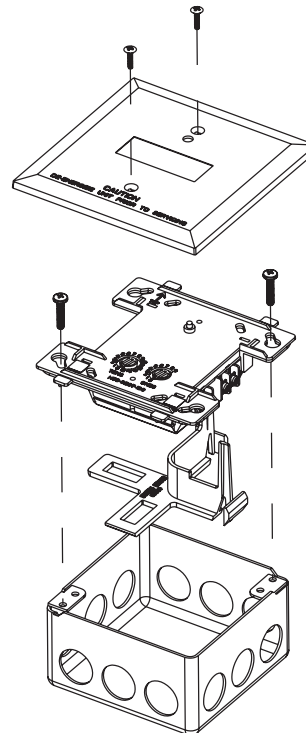

FIGURE 1B. JUMPER LOCATION:

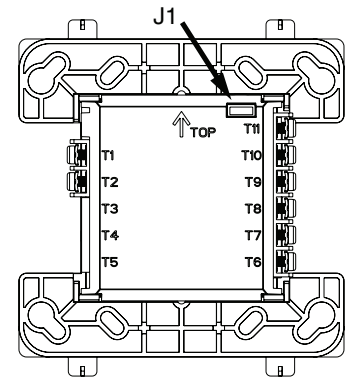

FIGURE 2B:

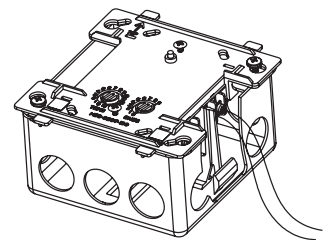
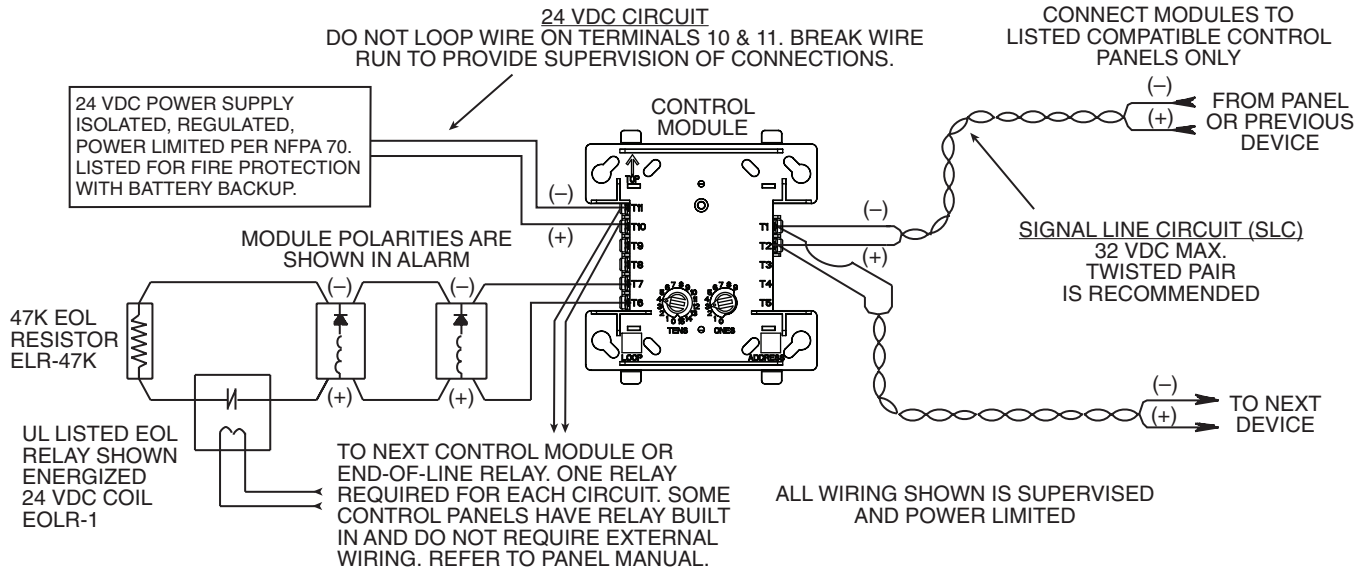

FIGURE 3. TYPICAL NOTIFICATION APPLIANCE CIRCUIT CONFIGURATION, NFPA STYLE Y:



*NOTE: ANY FAULT IN THE POWER SUPPLY IS LIMITED TO THAT ZONE AND DOES NOT RESULT IN A FAULT IN A SEPARATE ZONE.

C0947-00

FIGURE 4. TYPICAL FAULT TOLERANT NOTIFICATION APPLIANCE CIRCUIT CONFIGURATION, NFPA STYLE Z:

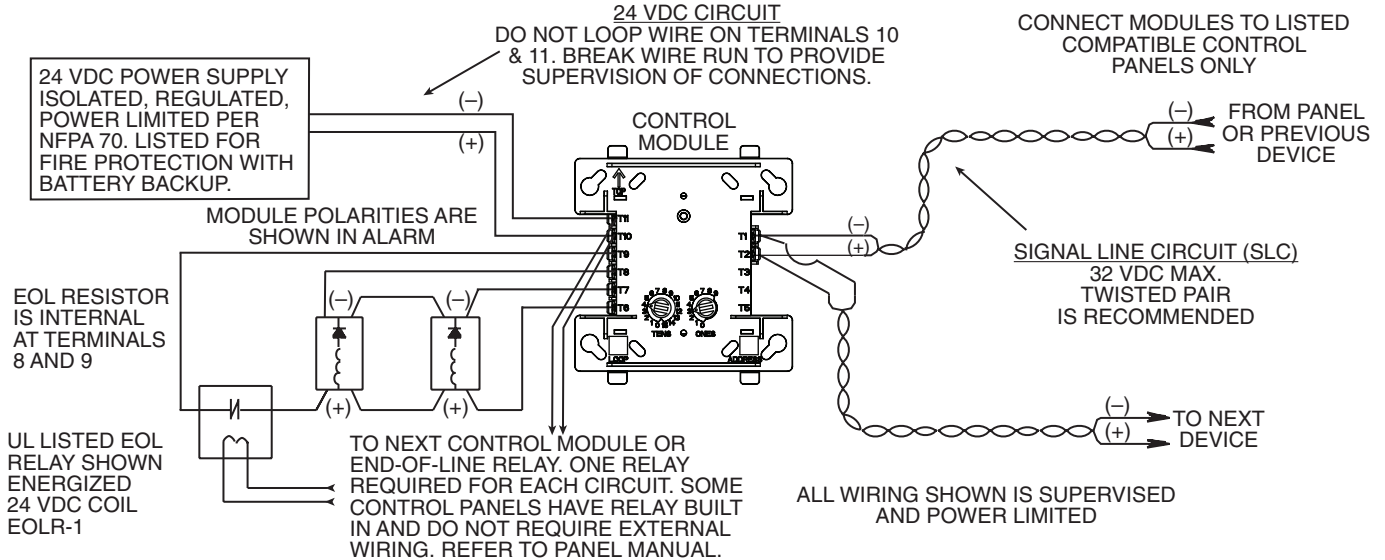

*NOTE: ANY FAULT IN THE POWER SUPPLY IS LIMITED TO THAT ZONE AND DOES NOT RESULT IN A FAULT IN A SEPARATE ZONE.

C0948-00

FIGURE 5. TYPICAL WIRING FOR SPEAKER SUPERVISION AND SWITCHING, NFPA STYLE Y:

AUDIO CIRCUIT WIRING MUST BE TWISTED PAIR AS A MINIMUM.
SEE NOTIFIER INSTALLATION MANUAL FOR DETAILED INFORMATION.

WIRES MUST BE SUPERVISED PER NFPA

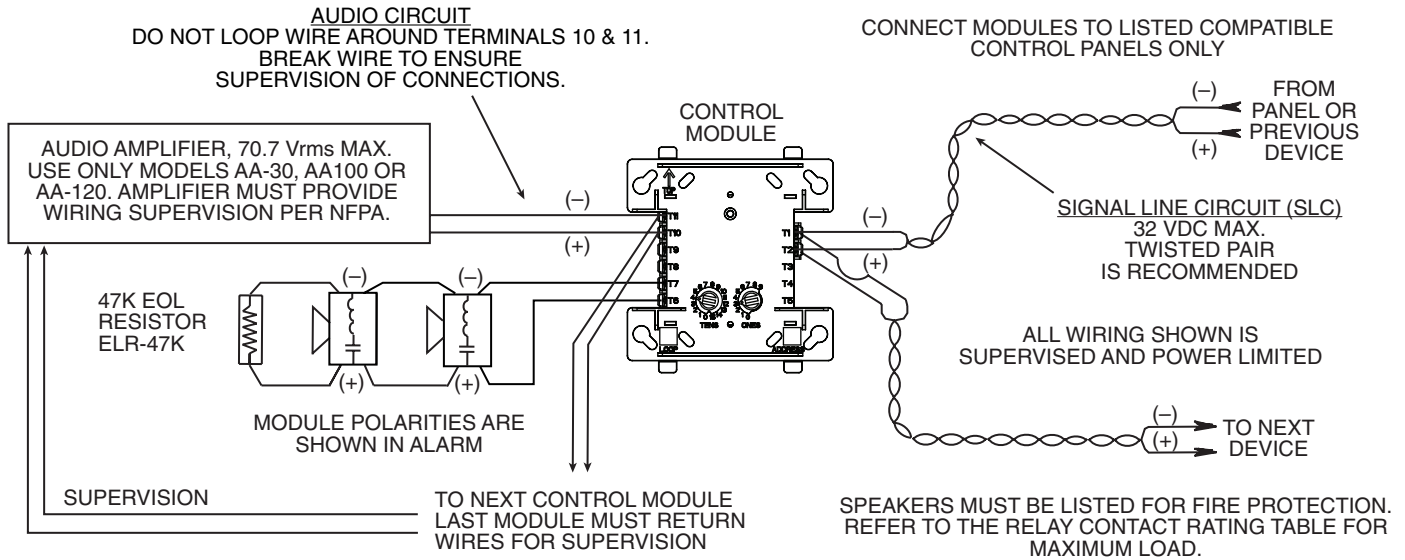

*NOTE: ANY FAULT IN THE POWER SUPPLY IS LIMITED TO THAT ZONE AND DOES NOT RESULT IN A FAULT IN A SEPARATE ZONE.

C0949-00

FIGURE 6. TYPICAL FAULT TOLERANT WIRING FOR SPEAKER SUPERVISION AND SWITCHING, NFPA STYLE Z:

AUDIO CIRCUIT WIRING MUST BE TWISTED PAIR AS A MINIMUM.
SEE NOTIFIER INSTALLATION MANUAL FOR DETAILED INFORMATION.

WIRES MUST BE SUPERVISED PER NFPA

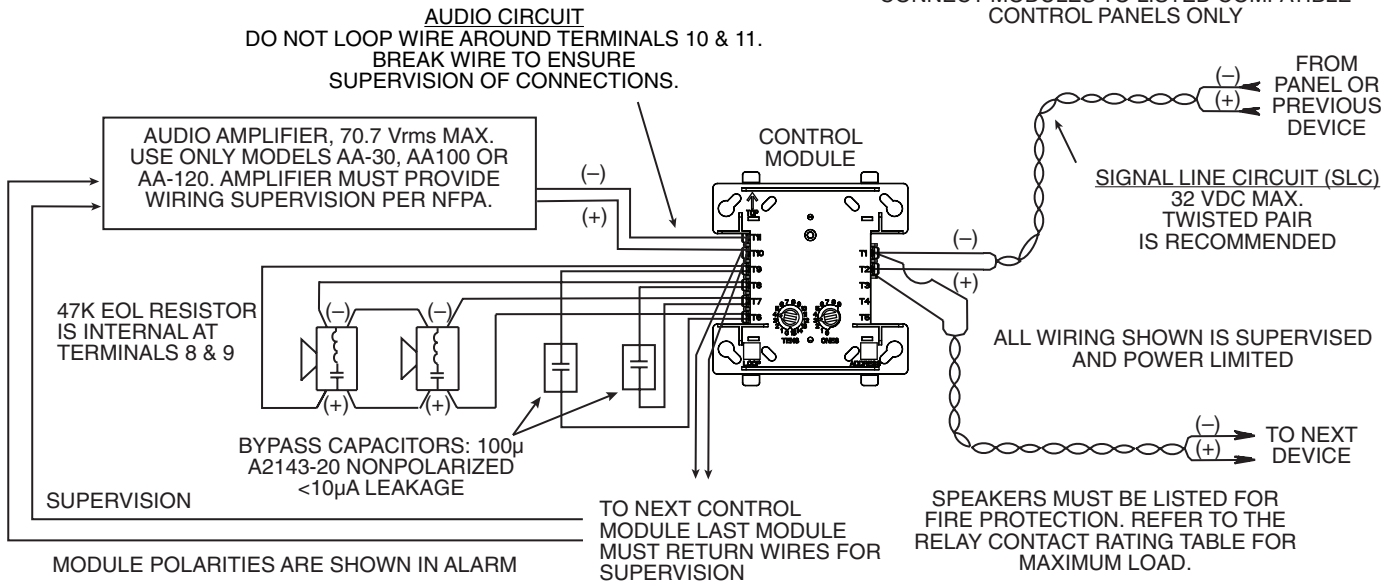

*NOTE: ANY FAULT IN THE POWER SUPPLY IS LIMITED TO THAT ZONE AND DOES NOT RESULT IN A FAULT IN A SEPARATE ZONE.

C0950-00

WARNING

All relay switch contacts are shipped in the standby state (open) state, but may have transferred to the activated (closed) state during shipping. To ensure that the switch contacts are in their correct state, modules must be made to communicate with the panel before connecting circuits controlled by the module.

